

The Urgency Of An Integrated Financial And Tax Reports Application: Viewed From The Awareness And Constraints Of Msmes

Nurul Aisyah Rachmawati*¹, Rizka Ramayanti², Rudi Setiawan³

¹Accounting Study Program, Faculty of Economics and Business, Universitas Triogi Jakarta, Indonesia.

²Accounting Study Program, Faculty of Economics and Business, Indonesia.

³Information Systems Study Program, Faculty of Creative Industries and Telematics, Universitas Trilogi Jakarta, Indonesia.

Abstract

This study aims to analyse the effect of awareness among Micro, Small and Medium Enterprises (MSMEs) on the urgency to implement an integrated financial and tax reports application. The study also seeks to analyse the effect of the urgency of implementing an integrated financial and tax reports application on the constraints faced by MSMEs. The study uses primary data obtained via a survey conducted in April–May 2021. Path analysis was used to analyse the data. The results show that MSMEs' awareness has a positive and significant effect on the urgency of implementing an integrated financial and tax reports application. The study also finds that the urgency of implementing an integrated financial and tax reports application has a negative and significant effect on MSMEs' constraints.

Keywords Awareness; Constraints; Financial Report; MSMEs; Tax Report.

Introduction

In accordance with Financial Accounting Standard No. 1 on the presentation of financial statements, the financial statements of an entity contain information regarding its financial position, financial performance and cash flow. As such, financial statements are one source of financial information that stakeholders refer to as part of their decision making. This applies to large-scale entities as well as micro, small and medium-scale entities.

However, Micro, Small and Medium Enterprises (MSMEs) continue to display relatively low levels of awareness when it comes to preparing financial and tax reports (Rachmawati, Ramayanti, & Setiawan, 2021). This reflects the low awareness of MSME actors in complying with Financial Accounting Standards and tax regulations. Thus, there are still many MSME

actors who do not compile financial and tax reports for their business. In addition to their low awareness, MSME actors often still face constraints in compiling financial and tax reports.

Therefore, the regulator has sought to assist MSME actors in preparing their financial and tax reports via a series of convenient measures. When preparing their financial reports, MSME actors can refer to SAK Entitas Mikro, Kecil dan Menengah (EMKM). This offers the advantage of being relatively simple to implement compared to other SAKs such as SAK Entitas Tanpa Akuntabilitas Publik (ETAP) and SAK based on International Financial Reporting Standards (IFRS). Meanwhile, to assist them in the preparation of tax reports, MSME actors can take advantage of tax incentives in the form of tax breaks and convenience to meet their tax obligations (Rachmawati & Ramayanti, 2016).

However, the convenience that the regulator has sought to provide is not necessarily sufficient to enable MSME actors to overcome the constraints they face in preparing their financial and tax reports. Accounting information systems offer a potential solution to such problems (Rumetna & Sembiring, 2017; Ria, 2018; Rahardja, Aini, Azizah, & Santoso, 2018; Juhardi & Khairullah, 2019; Aini, Rahardja, Arribathi, & Santoso, 2019). While various financial reporting applications have been developed specifically for MSMEs, integration remains very limited when it comes to a financial and tax reports application. This type of application can yield great benefits for MSME actors in the form of convenience when preparing financial and tax reports. Without it, MSME actors must adjust their financial statements with applicable tax provisions through a fiscal reconciliation process in order for them to become the basis for calculating, paying and reporting income tax for their business (Rachmawati & Martani, 2014).

The greater the awareness of the importance of financial and tax reports, the greater the effort on the part of MSME actors in ensuring that they compile their reports; for example, by using an integrated financial and tax reports application. It is also expected that a financial reports application to which tax reports are integrated will help in overcoming the constraints that MSME actors face in fulfilling their obligation to prepare financial and tax reports.

It is against this backdrop that this study aims to analyse the effect of MSME actors' awareness on the urgency of the integrated financial and tax reports application. The study also aims to analyse the effect of the urgency of the integrated financial and tax reports application on the constraints of MSME actors in preparing financial and tax reports. This study is the first step for further research in an effort to develop an integrated financial and tax reports application for MSME actors. This research is expected to provide benefits not only for SMEs but also for regulators. For MSMEs, the study can provide solutions to the problems they face in compiling financial and tax reports. For regulators, the study can encourage MSME actors to improve their compliance in preparing financial and tax reports.

Literature Review

MSME Awareness

According to Pawlik (1998), in psychology, awareness can be viewed from two aspects, namely functional and phenomenological. From the functional perspective, awareness is associated with attention. While in the phenomenological aspect, awareness is associated with internal awareness of one's experience (self-awareness and self-consciousness). In accordance

with Rachmawati, Ramayanti, and Setiawan (2021), awareness in this study is closely related to the awareness of MSME actors in preparing financial and tax reports. Based on the study, awareness will increase if MSME actors are aware of the importance of financial and tax reports. It will also increase if MSME actors comply with regulations related to financial and tax reports.

The Urgency of Integrated Financial and Tax Reports Application

Many previous studies have examined the role of accounting information systems in overcoming problems faced by MSME actors (Rumetna & Sembiring, 2017; Ria, 2018; Rahardja, Aini, Azizah, & Santoso, 2018; Juhardi & Khairullah, 2019; Aini, Rahardja, Arribathi, & Santoso, 2019). However, until now, there has been very limited research on the urgency of applications that integrate the process of preparing MSME financial and tax reports. In reality, financial statements and tax reports are very closely linked. Financial statements that were originally prepared based on SAK EMKM through the stages of the accounting cycle will be adjusted to the applicable tax provisions through the fiscal reconciliation process to become the basis for calculating, paying and reporting income tax (Rachmawati & Martani, 2014). The urgency of adopting an integrated financial and tax reports application can be seen from the costs and benefits of implementing it, as perceived by MSMEs. These actors will feel that an integrated financial and tax reports application is 'urgent' if the perceived benefits outweigh the associated costs. The reverse also applies: MSME actors will feel that the integrated financial and tax reports application is 'not urgent' if the perceived costs exceed the benefits..

MSME Constraints

The preparation of financial and tax reports is a challenge for MSME actors. In the context of financial reporting, although it is permissible to choose SAK EMKM, which is relatively simple compared to other SAKs, MSME actors still face several constraints (Rachmawati, Ramayanti, & Setiawan, 2021). The same applies to tax reporting. Here, MSME actors also often face constraints, despite being granted tax incentives in the form of tax breaks and convenience to fulfil their tax obligations (Rachmawati & Ramayanti, 2016). The constraints referred to include limited time, limited human resources, limited knowledge and others. The more constraints they face, the greater the tendency for MSME actors to be unable to compile financial and tax reports in accordance with the applicable regulations. Thus, the quality of the financial statements presented is low, which in turn makes it difficult for stakeholders to make the right decisions (Baas & Schrooten, 2006).

Hypothesis Development

MSME Awareness and the Urgency of Integrated Financial and Tax Reports Application

One factor that is thought to affect the urgency of the integrated financial and tax reports application is the awareness of MSME actors in preparing financial and tax reports. Relatively low awareness (Rachmawati, Ramayanti, & Setiawan, 2021) can result in MSME actors not compiling financial and tax reports in accordance with applicable regulations. However, greater awareness of the benefits of financial and tax reports will encourage MSME actors to make

extra efforts in preparing them. One such effort involves using an integrated financial and tax reports application, the benefits of which to MSME actors will outweigh the costs. This is because, in using a financial reports application that is integrated with tax reports, MSME actors are better equipped to fulfil their obligations in preparing financial and tax reports. In this case, it is hoped that MSME actors will find it easier to comply with SAK and applicable tax regulations when implementing the application.

Based on the arguments above, the study seeks to develop and test the following hypothesis:
H₁: Awareness of MSME actors of the importance of preparing financial and tax reports has a positive effect on the urgency of an integrated financial and tax reports application.

The Urgency of Integrated Financial and Tax Reports Application and the Constraints of MSME Actors

MSME actors also often face constraints in their efforts to prepare financial and tax reports (Rachmawati, Ramayanti, & Setiawan, 2021). The more constraints they face, the greater the tendency among MSMEs to not be able to compile financial and tax reports in accordance with the applicable regulations. Based on previous studies, accounting information systems play an important role in overcoming the problems and constraints that MSME actors face in preparing financial reports (Rumetna & Sembiring, 2017; Ria, 2018; Rahardja, Aini, Azizah, & Santoso, 2018; Juhardi & Khairullah, 2019; Aini, Rahardja, Arribathi, & Santoso, 2019). The use of an integrated financial and tax reports application can help to minimize these constraints due to the solutions it offers for MSME actors to fulfil their obligations in preparing financial and tax reports.

Based on the arguments above, the following hypothesis is proposed for development and testing:

H₂: The urgency of an integrated financial and tax reports application has a negative effect on the constraints of MSME actors in preparing financial and tax reports.

Framework

Following the hypothesis mentioned above, Figure 1 presents the framework of thought formed in this study.



Figure 1. Framework

Research Methods

Data and Sample

This study uses primary data from survey results that were obtained through the distribution of questionnaires. The sampling technique used in this research is purposive sampling. The respondents surveyed comprise MSME actors as stipulated in Article 35 of Government Regulation Number 7 of 2021 concerning Ease, Protection and Empowerment of Cooperatives and Micro, Small, and Medium Enterprises. Article 35 of this regulation states that the criteria

for MSMEs are based on business capital and annual sales results. In terms of business capital (excluding land and buildings for business premises), a business will be classified as:

- a. A micro business if it has a business capital of up to IDR 1 billion;
- b. A small business if it has a business capital of more than IDR 1 billion up to IDR 5 billion; and
- c. A medium business if it has a business capital of more than IDR 5 billion up to IDR 10 billion.

Meanwhile, in terms of annual sales, a business will be classified as:

- a. A micro-enterprise if it has annual sales of up to IDR 2 billion;
- b. A small business if it has annual sales in the range IDR 2 billion to IDR 15 billion; and
- c. A medium business if it has annual sales of between IDR 15 billion and IDR 50 billion.

Pilot Study

A pilot study was conducted before the questionnaires were distributed to the respondents. The pilot study was conducted in April 2021 on undergraduate Accounting students and lecturers at Universitas Trilogi who have a business. The aim was to test whether the questions and statements presented in the questionnaire could be easily understood. In addition, the data obtained from the pilot study was used to test the validity and reliability.

Analysis Method

Once all the questions and statements in the questionnaire could be understood, and they were considered to be valid and reliable, the questionnaires were distributed to the respondents who had set up businesses not only in Java but also outside Java. The data obtained were subsequently analyzed using path analysis.

Variable Measurement

Awareness Variable

The awareness variable in this study was measured using the technique proposed by Rachmawati, Ramayanti, & Setiawan (2021). The following indicators were used: 1) awareness of the importance of preparing financial and tax reports; and 2) awareness of the importance of complying with SAK EMKM and tax regulations. Based on these indicators, the greater the awareness of MSME actors about the importance of compiling financial and tax reports, the higher their awareness of the importance of compiling financial and tax reports. Furthermore, the higher the awareness of MSME actors in complying with SAK EMKM and tax regulations, the higher the awareness of the importance of preparing financial and tax reports. This study measured the first indicator based on a 4-point Likert scale with the possible responses ranging from 'strongly disagree' to 'strongly agree'. 'Strongly disagree' and 'disagree' indicate low awareness on the part of the respondents concerning the importance of preparing financial and tax reports; the opposite applies for the choices 'strongly agree' and 'agree'. This study used 'yes' or 'no' questions to measure the second indicator. According to Rachmawati, Ramayanti, & Setiawan (2021), this is the most appropriate type of question for measuring whether or not the respondent has a high awareness of the importance of complying with SAK EMKM and tax regulations by compiling financial and tax reports for their business.

Constraints Variable

The constraints variable was measured by providing several choices of constraints that are often felt by MSME actors when compiling financial and tax reports. These include limited time, limited human resources, limited knowledge and others (Rachmawati, Ramayanti, & Setiawan, 2021). In this case, the respondents could select more than one constraint. Furthermore, if there was no appropriate choice, the respondents could write down other perceived constraints. The choices of each respondent were then added up. The greater the number, the greater the constraints felt by the respondents in preparing financial and tax reports.

Urgency of Integrated Financial and Tax Reports Application Variable

The measurement of this variable involved using statements related to the level of urgency concerning the implementation of an integrated financial and tax reports application. The indicators included: 1) the needs of MSME actors for an integrated financial and tax reports application; 2) the benefits of an integrated financial and tax reports application; and 3) the minimal risks faced when implementing an integrated financial and tax reports application. Based on these indicators, the greater the need facing MSME actors, the greater the level of urgency for an integrated financial and tax reports application. Furthermore, the greater the benefits (i.e. low risk) felt by MSME actors, the higher the level of urgency for the integrated financial and tax reports application. The possible responses were presented on a 4-point Likert scale, ranging from 'strongly disagree' to 'strongly agree'. 'Strongly disagree' and 'disagree' indicated that the respondents felt an integrated financial and tax reports application was not urgent, and vice versa for the choices 'strongly agree' and 'agree'.

Results

Validity and Reliability Analysis

The data collected from the pilot study were tested for validity and reliability. The validity test was carried out using the item-test correlation. Meanwhile, the reliability test used Cronbach's alpha. The test results confirmed that the statements submitted in the questionnaire were both valid (Table 1) and reliable (Table 2).

Table 1. Validity Test Results

Variable	Indicator	Item-Test Correlation	Description
Awareness	S11	0,85	Valid
	S12	0,85	Valid
	S13	0,81	Valid
	S14	0,84	Valid
	S15	0,87	Valid
	S16	0,78	Valid
	S17	0,83	Valid
Urgency	U1	0,85	Valid
	U2	0,90	Valid

	U3	0,94	Valid
	U4	0,93	Valid
	U5	0,91	Valid
Constraints	K1	0,97	Valid
	K2	0,96	Valid

Table 2. Reliability Test Results

Variable	Cronbach Alpha	Description
Awareness	0,92	Reliable
Urgency	0,94	Reliable
Constraints	0,80	Reliable

Respondents' Profile

This study collected a total of 107 questionnaires for further analysis. Table 3 presents the profile of the respondents in the study. From the 107 questionnaires collected, 60 respondents were millennials, who tend to be technology responsive, while the remainder were over 40 years old. Furthermore, 68% of the respondents had taken higher education (Diploma/S1-S3). Concerning the respondents' type of business, 66% had a trading business, 22% were in services and 11% in manufacturing. Among these, 82% were in the form of individuals, with the remainder comprising business entities (such as CV, PT, Foundation). From the 107 questionnaires collected, 90 respondents operated their businesses in Java, which has better and more complete supporting facilities (including internet access and infrastructure) than other locations.

Table 3. Respondents' Profile

Age	Total	Percentage
17 – 40	60	56%
Lebih dari 40	47	44%
Education	Total	Percentage
Elementary School	4	4%
Junior High School	4	4%
Senior High School	26	24%
Undergraduate- Postgraduate	73	68%
Type of Business	Total	Percentage
Trade	71	66%
Service	24	22%
Manufacture	12	11%
Business Form	Total	Percentage
Individual	88	82%
Business Entity	19	18%
Business Location	Total	Percentage

Java	90	84%
Others	17	16%

Results Analysis

Figure 2 shows the results of the path analysis used to test the hypotheses. Goodness of fit testing was performed to ascertain whether the structural model formed is fit. The test results show that the value of the Comparative Fit Index (CFI) is 0.832. Meanwhile, the Tucker-Lewis Index (TLI) value is 0.796. Because the CFI and TLI values are close to 1, it can be concluded that the structural model formed is fit (Sarwono, 2010).

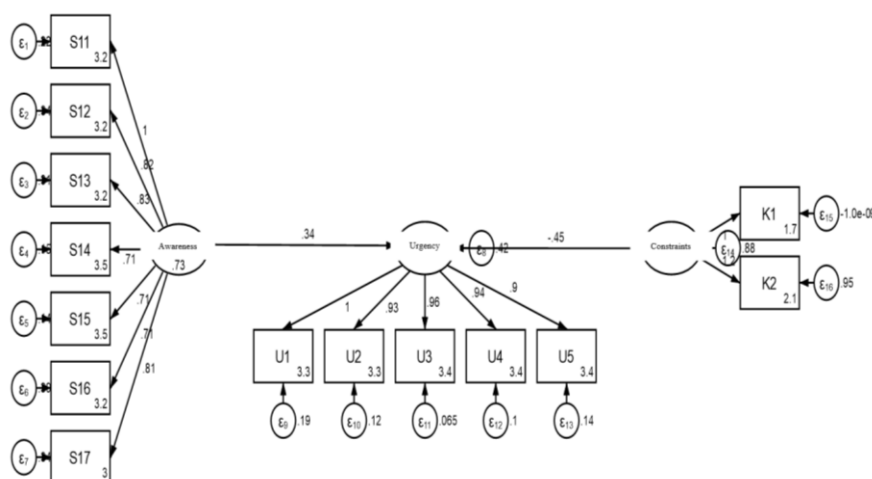

Figure 2. Path Analysis

The Effect of Awareness of MSME Actors on the Urgency of Integrated Financial and Tax

Report Applications

This section contains analysis of the results of the H1 test, namely whether the awareness of MSME actors of the importance of preparing financial and tax reports has a positive effect on the urgency of adopting an integrated financial and tax reports application. From Figure 2, it is known that the coefficient of awareness on the urgency variable is positive, at 0.34. In line with this, Table 4 shows that the P-value is less than 1% alpha. The results of this test indicate that the awareness variable has a positive and significant effect on the urgency variable at the 99% confidence level. This means that the higher the awareness of the importance of financial and tax reporting, the more urgent MSME actors will consider the integrated financial and tax reports application. Thus, H1 is accepted.

Table 4. Structural Model

Path	Prediction	Coefficient	z	P-value
Awareness → Urgency	+ (H1)	0,34	8,16	0,00***
Urgency → Constraints	- (H2)	-0,45	-5,06	0,00***
Notes:				
*** Significant at 99% confidence level				
** Significant at 95% confidence level				

* Significant at 90% confidence level

Higher awareness of the importance of financial and tax reports will encourage MSME actors to compile financial and tax reports in accordance with the applicable regulations. One way of doing this is for MSME actors to use an integrated financial and tax reports application. If they realize the importance of financial and tax reports, MSME actors will consider the adoption of an integrated financial and tax reports application to be urgent. This is due to the perception among MSME actors that the benefits of implementing an integrated financial and tax reports application will outweigh the costs. Financial reports applications that are integrated with tax reports can assist MSME actors in fulfilling their obligations to prepare financial and tax reports. In this case, it is hoped that implementing the application will make it easier for MSME actors to comply with SAK and applicable tax regulations.

The Effect of Urgency of the Integrated Financial and Tax Reports Application on the Constraints of MSME Actors

This section analyses the results of the H2 test, namely whether the urgency of implementing an integrated financial and tax reports application has a negative effect on the constraints of MSME actors in preparing financial and tax reports. Based on Figure 2, it is known that the coefficient of the urgency variable on the constraint variable is negative, at -0.45. In line with this, Table 4 shows that the P-value is less than 1% alpha. The results of this test therefore indicate that the urgency variable has a negative and significant effect on the constraints variable at the 99% confidence level. This means that the urgency of implementing an integrated financial and tax reports application can reduce the constraints faced by MSME actors in preparing financial and tax reports. Thus, H2 is accepted.

MSME actors will perceive that the adoption of an integrated financial and tax reports application is urgent if its benefits outweigh the costs. The benefits in question can be in the form of convenience and timeliness in the preparation of financial and tax reports. Meanwhile, the costs can be in the form of confidentiality and misuse of financial data for business. If the perceived benefits exceed the costs, the application is expected to be a solution for MSME actors to overcome the obstacles they face in preparing financial and tax reports. The constraints in question include limited knowledge, human resources and time. These results support previous research which states that accounting information systems can be used as a solution to overcome the problems faced by MSME actors (Rumetna & Sembiring, 2017; Ria, 2018; Rahardja, Aini, Azizah, & Santoso, 2018; Juhardi & Khairullah, 2019; Aini, Rahardja, Arribathi, & Santoso, 2019).

Conclusion

This study aimed to analyse the effect of awareness of MSME actors on the urgency of implementing an integrated financial and tax reports application. In addition, it aimed to analyse the effect of the urgency of an integrated financial and tax reports application on the constraints faced by MSME actors in preparing financial and tax reports. The conclusions drawn from the research results are presented in several sections as follows, according to the objectives of this study:

- a. Awareness of MSME actors has a positive effect on the urgency of adopting an integrated financial and tax reports application. This means that the higher the awareness of the importance of financial and tax reporting, the greater the tendency among MSME actors to consider the implementation of an integrated financial and tax reports application to be urgent.
- b. The urgency of the integrated financial and tax reports application has a negative and significant impact on the constraints of MSME actors. This means that an urgency to implement the integrated financial and tax reports application can reduce the constraints faced by MSME actors in preparing financial and tax reports. These results align with the research of Rumatna & Sembiring (2017); Ria (2018); Rahardja, Aini, Azizah, & Santoso (2018); Juhardi & Khairullah (2019); and Aini, Rahardja, Arribathi, & Santoso (2019).

Implication

For MSME actors, the results of this study imply that they must try to increase their awareness of the benefits of financial and tax reports. With high awareness, MSME actors will make extra efforts to compile financial and tax reports, for example through the use of an integrated financial and tax reports application. The use of such an application can minimise the obstacles faced by MSME actors in preparing financial and tax reports.

Limitations and Suggestions

This study has focused only on testing the direct effect of exogenous variables on endogenous variables. Further research may seek to use the variables in this study to examine the direct and indirect effects.

Reference

- Aini, Q., Rahardja, U., Arribathi, A. H., & Santoso, N. L. (2019). Penerapan Cloud Accounting dalam Menunjang Efektivitas Laporan Neraca pada Perguruan Tinggi. *Journal of Computer Engineering System and Science*, 4(1), 60-64.
- Baas, T., & Schrooten, M. (2006). Relationship Banking and SMEs: A Theoretical Analysis. *Small Business Economic*, 27, 127–137.
- GlobalStats, S. (2020). Mobile & Tablet Operating System Market Share Indonesia.
- Juhardi, U., & Khairullah. (2019). Sistem Pencatatan dan Pengolahan Keuangan pada Aplikasi Manajemen Keuangan E-Dompet Berbasis Android. *Journal of Technopreneurship and Information System*, 2(1), 24-29.
- Pawlik, K. (1998). The Neuropsychology of Consciousness: The Mind-Body Problem Re-addressed. *International Journal of Psychology*, 33(3), 185-189.
- Peraturan Pemerintah Nomor 7 Tahun 2021 tentang Kemudahan, Perlindungan, dan Pemberdayaan Koperasi dan Usaha Mikro, Kecil, dan Menengah.
- Rachmawati, N. A., & Martani, D. (2014). Pengaruh Large Positive Abnormal Book-Tax Differences terhadap Persistensi Laba. *Jurnal Akuntansi dan Keuangan Indonesia*, 11(2), 120-137.
- Rachmawati, N. A., & Ramayanti, R. (2016). Manfaat Pemberian Insentif Pajak Penghasilan dalam Kepatuhan Wajib Pajak UMKM. *Jurnal Akuntansi, Ekonomi dan Manajemen Bisnis*, 4(2), 176-185.

- Rachmawati, N. A., Ramayanti, R., & Setiawan, R. (2021). Tingkat Kesadaran dan Kesiapan Pelaku UMKM dalam Menyusun Laporan Keuangan dan Pajak. *Jurnal Akuntansi dan Bisnis*, 21(2).
- Rahardja, U., Aini, Q., Azizah, N., & Santoso, N. L. (2018). Efektivitas Akuntansi Online dalam Menunjang Proses Rekonsiliasi. *Nusantara Journal of Computers and Its Applications*, 3(2), 105-112.
- Ria, A. (2018). Analisis Penerapan Aplikasi Keuangan Berbasis Android pada Laporan Keuangan UMKM Mekarsari, Depok. *Sosio E-kons*, 10(3), 207-219.
- Rumetna, M. S., & Sembiring, I. (2017). Pemanfaatan Cloud Computing bagi Usaha Kecil Menengah (UKM). *Prosiding Seminar Nasional Geotik* (pp. 1-9). Surakarta: Universitas Muhammadiyah Surakarta.
- Sarwono, J. (2010). Pengertian Dasar Structural Equation Modeling (SEM). *Jurnal Ilmiah Manajemen Bisnis*, 10(3), 173-182.
- Standar Akuntansi Keuangan Entitas Mikro, Kecil, dan Menengah (2016).
- Standar Akuntansi Keuangan Entitas tanpa Akuntabilitas Publik (2009).
- Standar Akuntansi Keuangan Berbasis IFRS.
- Undang-Undang Nomor 28 Tahun 2007 tentang Ketentuan Umum dan Tata Cara Perpajakan.
- Undang-Undang Nomor 11 Tahun 2020 tentang Cipta Kerja.
- Weygant, J. J., Kimmel, P. D., & Kieso, D. E. (2018). *Pengantar Akuntansi 1 Berbasis IFRS*. Jakarta: Salemba Empat.